



FL-110 Linear Feeder

Designed for Multiple Bottle Applications



*Linear feeder with left hand exit shown.

Product Overview:

Hoppmann's FL-110 is designed to economically unscramble a wide variety of bottle applications. Delivery rates vary from slow to moderate speeds depending on application. The linear feeder features snap-in/snap-out vanes for quick and easy changeover - no tools needed. The FL-110 is standard with an integral Hoppmann prefeeder and discharge/exit conveyor.

Product Specifications:

	ANSI
A. Overall Height	100" ± 2"
B. Discharge Height	36" ± 2"
C. Overall Length	175"
D. Overall Width	105"
E. Hopper Load Height	48.25" ± 2"

Standard Models:

Part Number	FL13RXXDYA (Right Hand Exit)	FL13LXXDYA (Left Hand Exit)
Motor Style	DC	DC
Motor Voltage	90V	90V
Horsepower	3/4 hp	3/4 hp
Weight Untooled	1700 lbs	1700 lbs
Supply Hopper Capacity	40 ft ³	40 ft ³

Standard Features:

- Powered recirculating conveyor
- Quick change tooling
- Bulk storage hopper
- Stainless steel pre-orientation chute
- Mechanically timed outfeed conveyor
- Steel-It finish
- Polycarbonate covers
- Manual conveyor advance wheel
- Air clutch drive protection

Available Options:

- Powered singulation belt wiper
- Puck system
- Air rinsing
- AC Motor

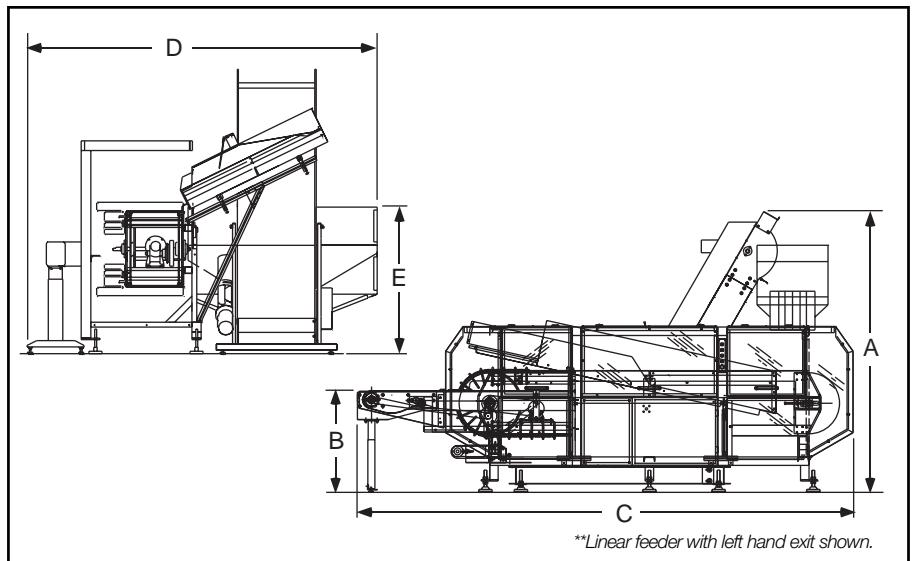

**Linear feeder with left hand exit shown.

Hoppmann Corporation strives to improve its products and reserves the right to change or discontinue specifications & designs shown in this brochure without notice and without incurring obligation. 08/05

Packaging - Processing
Bid on Equipment
 1-847-683-7720
www.bid-on-equipment.com

Hoppmann Corporation Headquarters
 13129 Airpark Drive • Suite 120 • Elkwood, VA 22718
 Tel: 540.829.2564 • 800.368.3582 • Fax: 540.829.1724
www.hoppmann.com • email: feeder@hoppmann.com

Hoppmann Corporation Manufacturing
 P.O. Box 879 • 291 Dillard Rd. • Madison Heights, VA 24572
 Tel: 434.929.4746 • 800.543.0915 • Fax: 434.929.4959
www.hoppmann.com • email: feeder@hoppmann.com