



The CTM 360a-HS Series Label Applicator is a rugged, versatile applicator loaded with standard features that are optional on most other applicators.



Setting Global Standards
One Customer at a Time

360a-HS High Speed Labeler

Features:

The CTM 360a-HS Series Label Applicator is a rugged, versatile applicator loaded with standard features that are optional on most other applicators. The 360a-HS Series Applicator can be configured as a blow on, merge or tamp applicator. Each module can also be easily switched from right to left hand dispensing mode. Each applicator is equipped with a 20" non-powered unwind/powered rewind.

Stepper Motor

The 360a-HS stepper drive will dispense labels at speeds of 2100 inches/minute.

Control

The 360a-HS is equipped with state-of-the-art electronics featuring Dual Microprocessor control. One 32-bit processor supervises the application program while the digital signal processor (DSP) supervises the motion loop resulting in faster response times and improved application accuracy. The 360a-HS controller is also equipped with onboard I/O prewired to external connectors to accommodate the following:

- Low Label Conditions
- Web Break and End of Web Conditions
- Tamp Extend & Tamp Home Switching
- Rate & Velocity Compensation
- Profiling
- Zero Downtime Configuration of Applicators

Each machine is shipped preprogrammed with prewired connectors to control all of the above accessories. Some additional hardware may be required.

The electronic control assembly has been packaged as a module. Each control module can be easily removed for repair or replacement, eliminating costly downtime and servicing costs.

Electrical:

108-132 VAC, 50/60 Hertz, Single Phase, 10 amps.

Air Consumption:

Up to 4 CFM at 60-90 psi.

Labeling Speeds:

Programmable to 1500 inches per minute, to 2100 inches per minute. With oversize unwind and rewind. Programmed with speed profiling ability.

Product Sensing:

Retroreflective scanner provided as standard, other types available

Label Sizes:

	Minimum	Maximum
Air Blow	3/4" wide x 3/4" L	5" wide x 5-1/2" L
Merge	3/4" wide x 3/4" L	5" wide x 20" L
Tamp	3/4" wide x 3/4" L	5" wide x 10" L

Label Roll Size:

Maximum 20" OD x 3" ID core

Optional 16" OD x 3" or 6" ID cores

Label Placement:

+/- 1/32"

Dimensions:

Air Blow 39" wide x 38-1/2" Tall x 27-1/2" Deep

Merge 43" wide x 40" Tall x 27-1/2" Deep

Tamp 42" wide x 37" Tall x 27-1/2" Deep

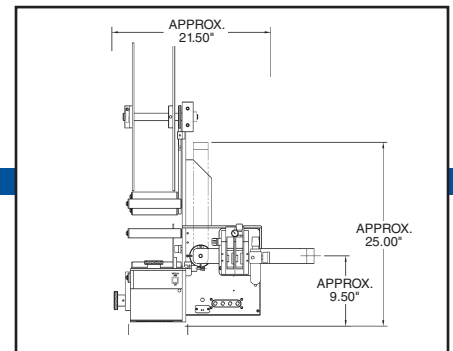
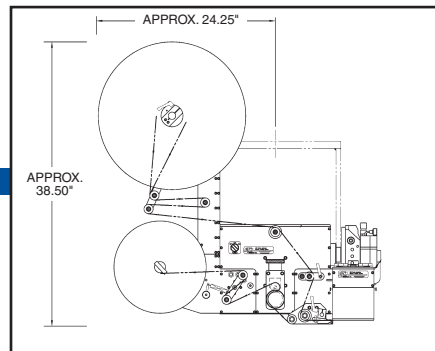
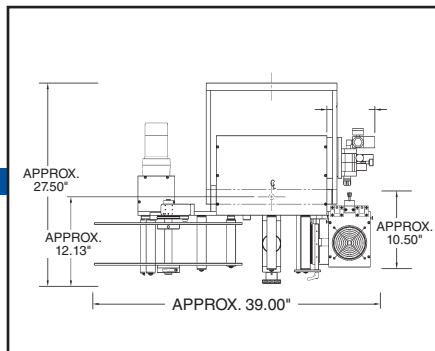

Distributed By:



1318 Quaker Circle
P.O. Box 589
Salem, Ohio 44460
(330) 332-1800

