



SALAD SPINNER ES-200

Capacity per cycle: 12 Kg. / 20 gal.



SALES DESCRIPTION

Fast, sleek, quiet, user-friendly, safe, smooth running commercial salad spinner, designed to efficiently dry up to 12 Kg. / 20 gal. of salad per cycle at a maximum speed of 900rpm.
 Portable. Equipped with locking wheels. Cycle memory. 2-speed-appliance.

- ✓ Sammic salad spinners dry lettuce and other vegetables in as low as 1-3 minutes owing to their fast speed (900 r.p.m), ensuring good product quality.
- ✓ Equipped with powerful three-phase motors controlled by highly reliable electronic speed variator, which enables the salad dryer to be connected to a single-phase electrical mains supply.
- ✓ Stainless steel construction.
- ✓ Lightweight and removable stainless steel basket.
- ✓ Compact geometry: easily fits under conventional standard counter-tops.
- ✓ Equipped with castors allowing the operator to wheel unit around the kitchen and under a countertop for easy storage.
- ✓ Transparent, heavy duty lid for ease of control.
- ✓ Lid equipped with a self-opening mechanism, for ease of access to basket.
- ✓ User-friendly, waterproof control panel. Advanced features
- ✓ Electronic timer with 3 fixed cycles.
- ✓ Weight distribution detection system (VCS) to prevent rattling of the unit. Self lock-in mechanism to ensure basket is properly secured before cycle starts.
- ✓ Braking system safety mechanism: allowing basket to stop turning as soon as lid opens.
- ✓ An indicator appears when the door is open.

INCLUDES

- ✓ Castors with brake.
- ✓ Stainless steel drying basket.

OPTIONAL

- Additional stainless steel drying basket.

ACCESSORIES

- Stainless Steel Basket set

SPECIFICATIONS

Capacity per load: 20 gal
 Drainer hourly production: 500 lbs - 1600 lbs
 Timer (min-max): 60 " - 120 " - 180 "
 Motor speed: 900 rpm
 Total loading: 0.75 Hp
 Electrical supply: 120V / 50-60 Hz / 1~ (5 A)

Basket dimensions: 14.65 " x 18.3 "

External dimensions (WxDxH)

- ✓ Width: 21.3 "
 - ✓ Depth: 29.5 "
 - ✓ Height: 32.1 "
- Net weight: 115 lbs

AVAILABLE MODELS

1000710 Salad drier ES-200 230/50-60/1

1000712 Salad drier ES-200 120/50-60/1

* Ask for special versions availability

DYNAMIC PREPARATION
COMMERCIAL SALAD SPINNERS



product sheet
updated 02/24/22



SALAD SPINNER ES-200

Capacity per cycle: 12 Kg. / 20 gal.



DYNAMIC PREPARATION
COMMERCIAL SALAD SPINNERS

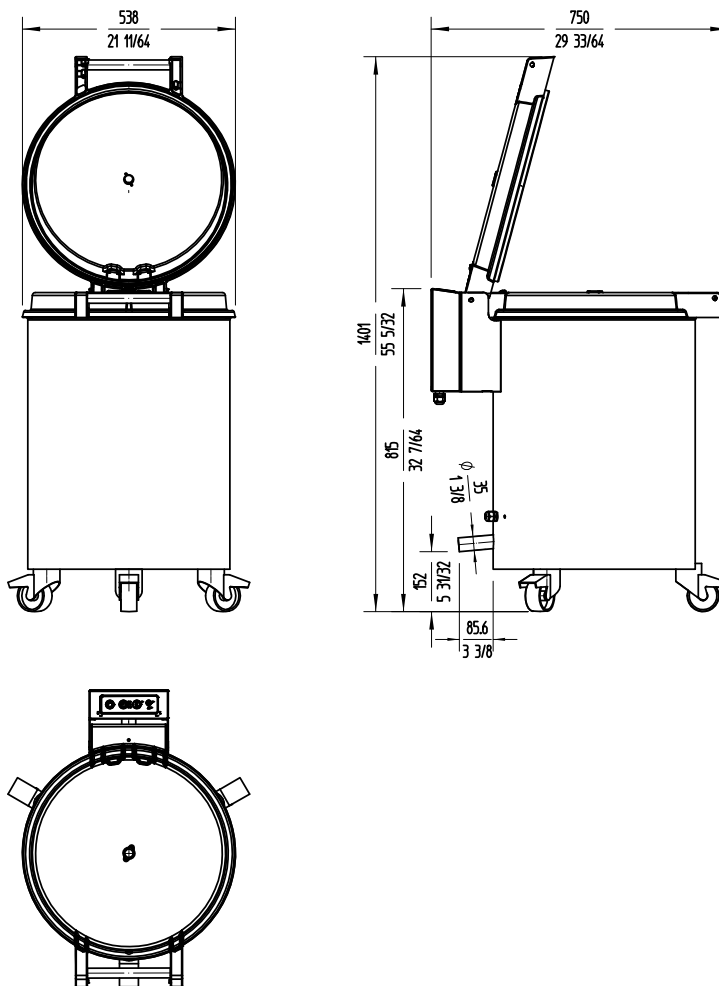

sammic | www.sammic.us
Food Service Equipment Manufacturer

usa@sammic.com
1225 Hartrey Avenue
60202-1056 Evanston, IL

phone +1 (224) 307-2232
toll free +1 844 275 3848



Project	Date
Item	Qty
Approved	

product sheet
updated 02/24/22