

710



MANUFACTURING

The Shape of Things to Come



710



Improved stack and count system

The state-of-the-art counter is not limited by the number of patties. You are able to set the counter for any number of patties in a 6" high stack.

250 Lb. Tilt Hopper

The 250 lb. product hopper is designed to tilt to the side, making cleanup easy!

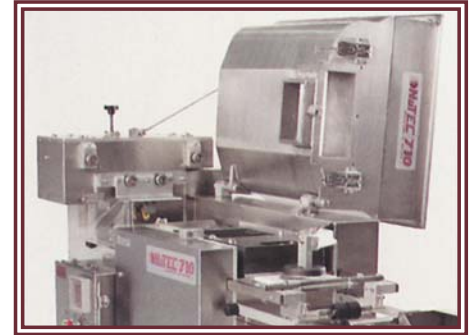

Quick change-overs

Unique design eliminates constant adjusting. The knock out cup assembly does not need adjustment every-time K.O. cup is changed, reducing change-over time.

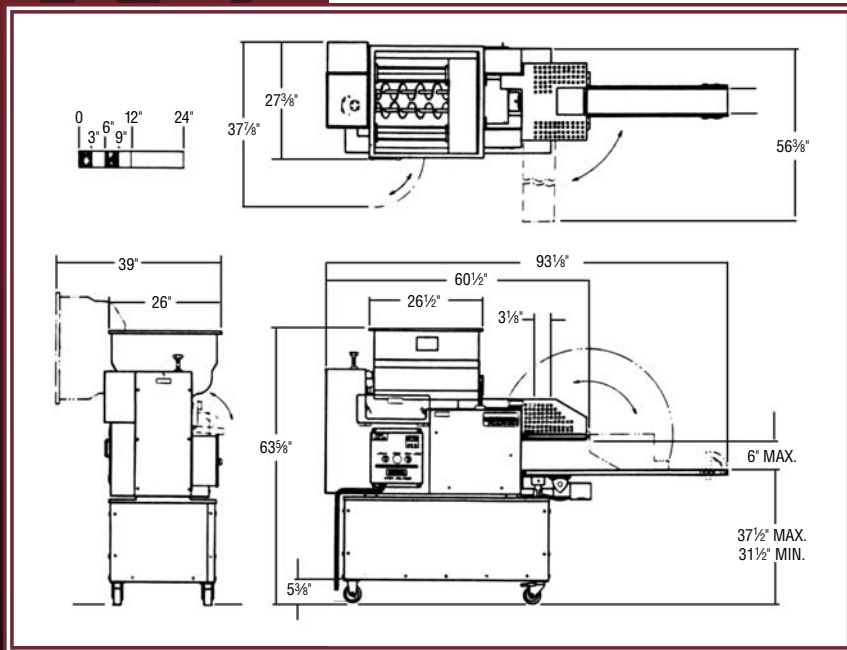

Product Specifications

- "NuTECtured" Patty Forming System
- 3600 patties per hour
- Max. patty size—10 oz.
- Mold Plate Thickness—3/16" to 1"
- 250 lb. product hopper
- USDA approved

Electrical Specifications

- 200, 208, 230, 380, 420, 460, 575 Volts, 3PH, 50/60 HZ
- 5 HP Main Drive
- Knock out heater
- Safety interlocked
- NEMA 4 stainless steel enclosure

Paper Feed Specifications

- 4 ft. packoff conveyor
- Standard paper sizes 4-1/2", 5", 5-1/2", and 6" square
- Electronic counter

