



Solutions for Waste & Recycling

Harmony
ENTERPRISES, INC.



M60MD

Vertical Baler



The M60MD Vertical Baler is the Ideal Solution For:

- Shopping Centers
- Supermarkets
- Hotels/Motels
- Hospitals
- Industrial/Commercial Applications
- The Military
- Department Stores

See The Video At:

<https://youtu.be/dQYL4aNIO7E?t=1>

This space saving low profile workhorse operates under a standard ceiling.

Compare these features of the M60MD with the competition:

- Operates under an 8 foot ceiling height
- Rolls through any 3½' x 7' doorway
- This machine is ideal for baling and recycling cardboard, shrink wrap film and other recyclables
- Produces 700-800 pound corrugated bales

- Fast 33 second cycle time reduces your work time
- Shipped upright for easy unloading and placement at the work site
- Cylinder safety cable standard on all M60MD models

The M60MD Vertical Baler, another great idea from Harmony Enterprises...*The Undisputed Leader in Quality Manufacturing.*



www.harmony1.com

Recycling and Waste Solutions on a Global Scale.

M60MD Vertical Baler

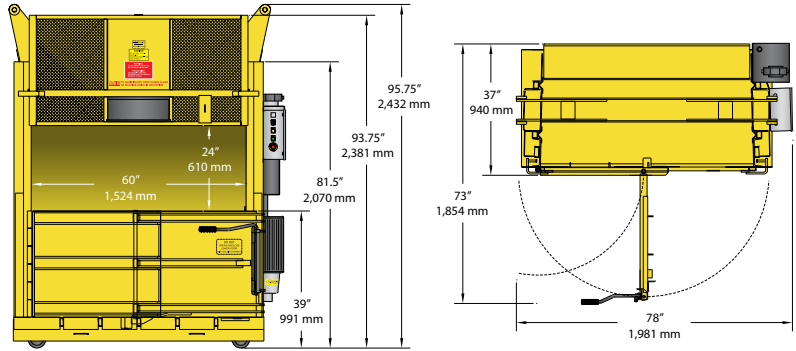

Standard M60MD Features:

- Control panel is UL® listed
- The operator loads, compacts, ties, and hydraulically ejects bales from the front of the machine, the compression cycle is fully automatic
- Physical durability is assured through solid construction
- Safety interlocks and shielding of all shear and pinch points makes the M60MD the safest 60" baler available today
- 5 horsepower motor for energy efficient operation
- Energy efficient two-stage pump provides maximum compaction pressure and rapid operating cycles with minimum horsepower
- Meets or exceeds all ANSI and OSHA safety standards

SPECIFICATIONS

Bale Size	30" x 60" x up to 30 high" (762 mm x 1,524 mm x up to 762 mm)
Bale Weight (corrugated cardboard)	700 - 800 lbs. (318 - 363 kg)
System Pressure	2,300 PSI
Bale Pressure	57,805 lbs. (26,220 kg)
Cycle Time	33 seconds
Cylinder	Twin 4" bore (102 mm) 32" stroke (813 mm)
Motor	5 horsepower, 3,450 RPM
Pump	Two-stage
Electrical Power	208/230/460 volt, 3 phase, 60 hz
Bale Eject	Hydraulic
Bale Tying	Wire twine, strapping

DIMENSIONS

Loading Door Opening	24" x 60" (610 mm x 1,524 mm)
Overall Depth	37" (940 mm)
Overall Width	78" (1,981 mm)
Depth with Door Open	73" (1,854 mm)
Shipping Height	81.5" (2,070 mm)
Shipping Weight	4,000 lbs. (1,814 kg)
Operating Height	95.75" (2,432 mm)

Specifications subject to change without notice.



SAI GLOBAL
ISO 9001
Quality

Harmony Enterprises, Inc. 704 Main Avenue North Harmony, MN 55939 USA
1.800.658.2320 toll free | 1.507.886.6666 international | 1.507.886.6706 fax
Email us at info@harmony1.com or visit us online at www.harmony1.com

©2009 Harmony Enterprises, Inc. All rights reserved. Form HEL_M60MD_US 07/09 SC