



SMOOT

TAYLOR

# VALVE BAG AUGER PACKER

## MODEL APV

Magnum Systems' Model APV is designed to handle products that aerate, bind, cake, or bridge easily. The variable speed auger option utilizes bulk and dribble feeding technology ensuring fast and accurate weight measurement.

### USE SPEED AND PRECISION TO PACKAGE DIFFICULT TO FEED OR CONTROL MATERIALS

#### Features

- Product agitator for material conditioning
- Regenerative blower
- Pneumatic bag clamp
- Dropout bottom for ease of cleaning
- T-4000 weigh controller with digital readout

#### Optional Features

- Stainless steel construction/contact areas
- Pneumatic bag kicker
- Dual set point
- Bag settler
- Container platform and lift
- Removable screws and agitator
- Bag inflator with spout
- T-3000 weigh controller
- TRV-1000 robotic bag placer
- TRUSeal ultrasonic sealer
- Integrate conveying and palletizing equipment

#### Materials Typically Handled

- Flours and starches
- Industrial chemicals
- Sandy cement grouts
- Oily products with low-bulk density



One Partner For All Your Material Handling Needs.

# VALVE BAG AUGER PACKER

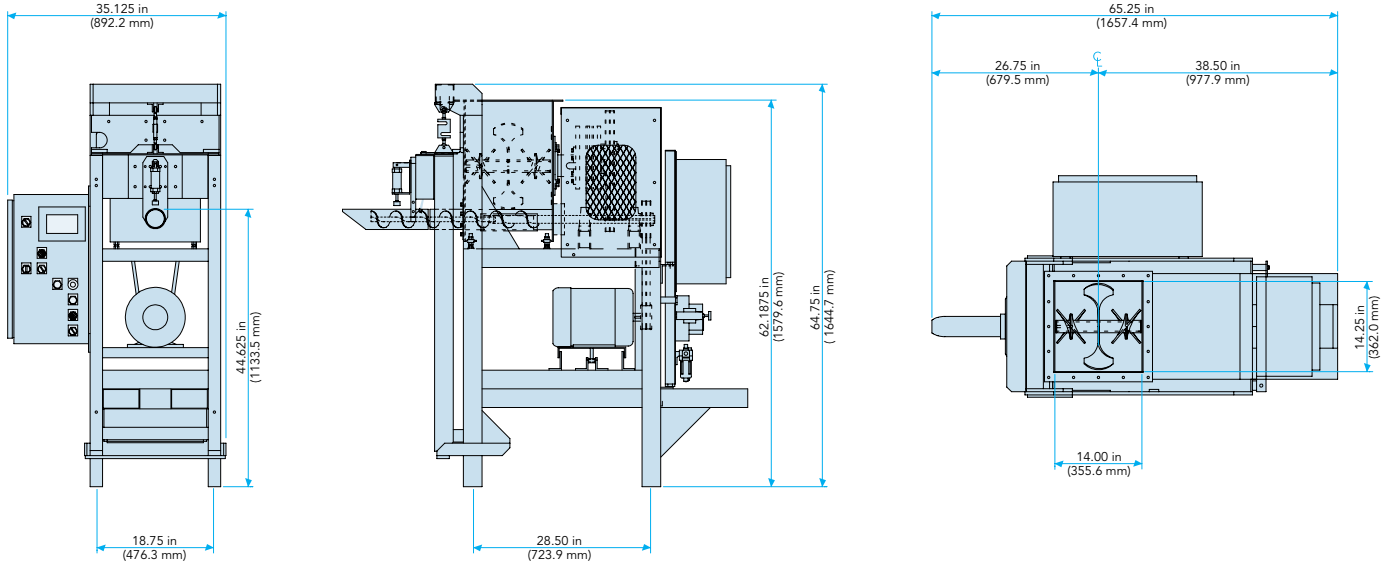

Diagram dimensions are for reference only\*

## SPECIFICATIONS

Speed	Up to 5 BPM
Accuracy	Up to 0.4%
Bag Weight Range	15 to 125 lb (6.8 to 56.7 kg)
Scale	Analog, digital
Construction	Tubular carbon steel blasted and painted
Product Hopper	4,000 cubic inch (6,550 cubic centimeter) capacity (standard)
Spout Size	2.5 in (63.5 mm) diameter up to 4 in (101.6 mm) diameter
Electrical Requirements	230/460 volt, 3 phase, 60 hertz
Air Requirements	90 PSI, 2 ft 3 per minute, 200-300 CFM (dust control recommended)
Enclosures	NEMA12



## ULTRASONIC SEALER

- Ultrasonic waves alter molecular structure of sealing agent without heat, which reduces product degradation
- Rigid mount setup at filling source decreases amount of bag movement while maintaining bag shape
- Ultrasonic waves displace product from seal area providing a clean, positive seal
- Helps prevent product loss during shipping
- Capable of both plastic and paper valve sealable bags
- Works well with dusty, fluid, powder, and hydroscopic products



©2024 Magnum Systems, Inc. All rights reserved. Catalog number MS.1028.0824



[www.magnumsystems.com](http://www.magnumsystems.com)

Toll Free 800.748.7000 Fax 913.362.7863  
7945 Flint Street, Lenexa, KS 66214