

# CONVEYORIZED TARGET SAUCE APPLICATOR

Quantum's QTMC5 ConveyORIZED Target Sauce Applicator deposits sauce onto products at speeds up to 80 feet per minute while maintaining a clean border. The QTMC5 is a compact, simple to set-up and easy to operate system that is USDA compliant, washdown capable, and easy to clean. Perfect for single lane, wholesale production, test kitchens, and R & D Facilities!



\* Shown with Optional Hopper Transfer Pump

MODEL #QTMC5

## SPECIFICATIONS

### PRODUCT:

Pizza Sauce, BBQ Sauce, Cheese Sauce, Ranch Dressing

### SAUCE HOPPER:

Standard 12 Gallon Hopper (45.4 liters)

### UTILITY REQUIREMENTS:

200 – 240 Volts, 1 Phase, 5 Amp Circuit 50/60 Hz  
80 PSI @ 6 SCFM

### OPTIONS:

Optional 7 Gallon (26.5 liters) Conical Hopper  
Optional Hopper Transfer Pump Assembly

### PRODUCTION RATES UP TO:

6"	@	110+ Pizzas Per Minute	6,600+ Per Hour
8"	@	110+ Pizzas Per Minute	6,600+ Per Hour
10"	@	96 Pizzas Per Minute	5,760 Per Hour
12"	@	80 Pizzas Per Minute	4,800 Per Hour
14"	@	68 Pizzas Per Minute	4,080 Per Hour
16"	@	60 Pizzas Per Minute	3,600 Per Hour

### FEATURES:

- ✓ Heavy Duty Stainless Steel Frame
- ✓ Cantilevered, Flat Belt Conveyor
- ✓ Locking Swivel Casters with No Exposed Threads
- ✓ One Sauce Pattern Included
- ✓ Nozzles and Custom Patterns Available
- ✓ Wash Down Capable
- ✓ No Tools Required for Sanitation
- ✓ Auto Centering
- ✓ Start/Stop Interconnectivity
- ✓ Allen Bradley PLC
- ✓ Large Intuitive Color Touch Screen
- ✓ 3 Color Signal Tower
- ✓ 50 User Defined Recipes
- ✓ UL 508A Controls



MORE INFO



WWW.Q-T-S.COM

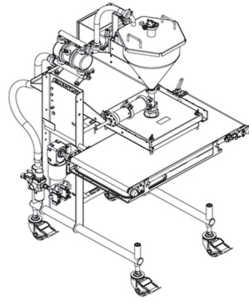
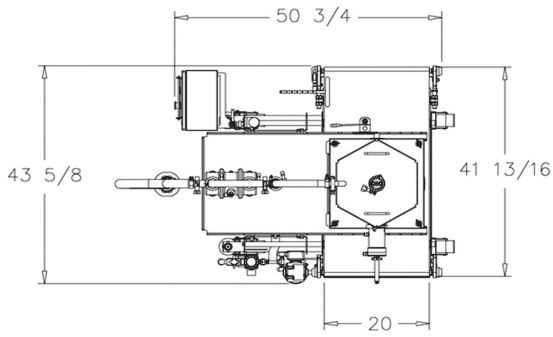

Optional Hopper  
Level Sensor



No Tool Required  
Belt Removal

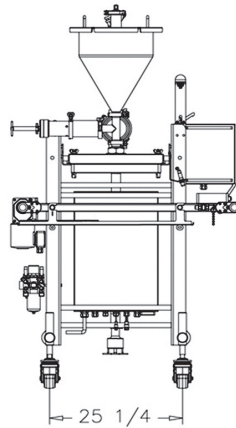
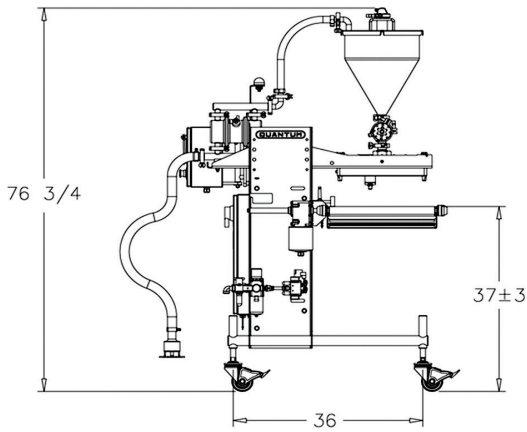

Large Intuitive Color  
Touch Screen



Floating Adjustable  
Lane Guide



Optional Transfer Pump



Heavy Duty Locking Casters  
With No Exposed Threads



No Tools Required  
Quick Change Patterns



Removable Cantilevered  
Conveyor

**QUANTUM<sup>®</sup>**

**PORTION & APPLY**

TOP IT | FILL IT | SLICE IT

CONTACT US: +1 815.464.1540  
INFO@Q-T-S.COM | WWW.Q-T-S.COM  
U.S.A.