



# RT7000

## HIGH-SPEED NET-WEIGH SCALE



The RT7000 is Taylor Products' premium, net-weigh packaging machine with exact weighments, high production capacity and operator features in one package. A gravity-fed, primary fill cycle is complimented by a vibratory-fed, secondary cycle to provide the fastest possible rates and the most precise accuracy when packaging free-flowing products like grains, pet foods or granular products.

### WEIGHTS FROM 15 LBS TO 110 LBS

- Weigh mast design, no hangers or pivots
- Automated calibration
- Electronically-controlled, adjustable flow gates
- Quick remove components for easy maintenance
- Weigh buckets with rounded corners, no product hang-up
- Infinite vibrator trim fill
- Simplex or duplex configuration
- For grains and granular products



Custom Packaging and  
Container Handling Equipment



# RT7000 SPECIFICATIONS

Diagram dimensions are for reference only

## DUPLEX CONFIGURATION

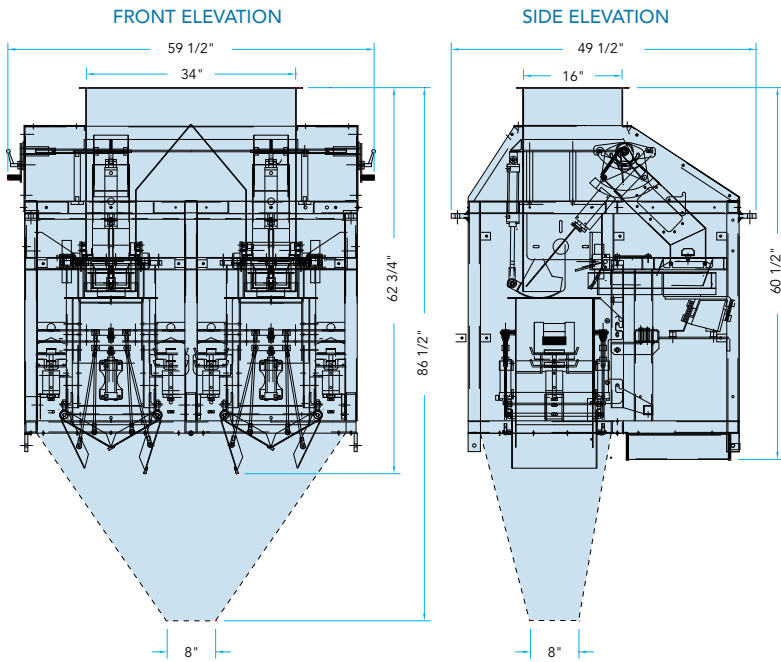

## SIMPLEX CONFIGURATION

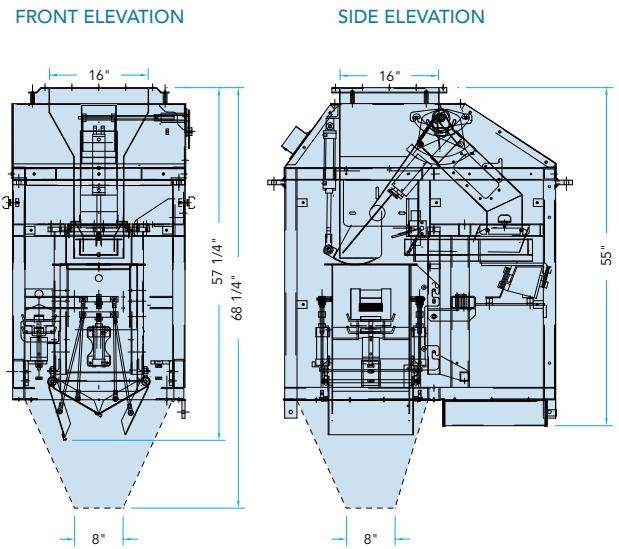

\*All transition chutes shown are optional

<b>Dimensions</b>	59.5 in x 53.5 in x 66.375 in (1,511.3 mm x 1,358.9 mm x 1,685.9 mm)
<b>Speed</b>	Duplex up to 22 bpm, simplex up to 12 bpm at 50 lbs
<b>Accuracy</b>	Up to ±50 grams (±0.1 lbs)
<b>Weight Range</b>	15 lbs to 110 lbs (6.8 kg to 50 kg)
<b>Construction</b>	Carbon steel, blasted and painted; product contact 304 stainless steel
<b>Electrical Requirements</b>	120 V, single phase
<b>Air Requirements</b>	90 psi, 5 cfm
<b>Standard Features</b>	Automated calibration, quick-remove components, weigh buckets with rounded corners, and vibrator speed control
<b>Options Available</b>	Bag clamps for manual placement lines, weight data collection Auto calibration available with upgraded T3000 option



### AUTO-CALIBRATION

- Easy to remove
- Quick access



### VIBRATORY TRIM FEED

- Quick clean
- Cut-off gate



©2014 Magnum Systems, Inc. All rights reserved. Catalog number: MS.1046.0914



[www.taylorproducts.com](http://www.taylorproducts.com)

Toll Free 888.882.9567 Phone 620.421.5550 Fax 620.421.5531

2205 Jothi Avenue, Parsons, Kansas 67357