

GENTLY AND ACCURATELY DIVIDES DOUGH **1000**

V₄-TWIN DIVIDER

STRESS FREE SYSTEM and GRAVIMETRIC METHOD

VX222

The Twin Divider accurately portions the dough sheet at a desired weight or length. Ideal for production of smaller products.

- *Simply interchangeable between single and twin row production without changing blades*
- *Changeable Roller Width by Optional V-Roller*
- *User-friendly Operation by Movable Operation Panel*
- *Easy Cleaning & Maintenance*



DIVIDING RANGE: 1-row 150-1200g 2-rows 75- 600g

PRODUCTION CAPACITY: 1000 kg/h*

*When the "V-Roller" width is set at 145 mm (Option)
*V-Roller : Dough Feeding Roller



V4-TWIN DIVIDER 1000

Working Table *Option

Changeable Roller Width and Adjustable Thickness

Dough width adjustment made easy by just switching the V-Rollers

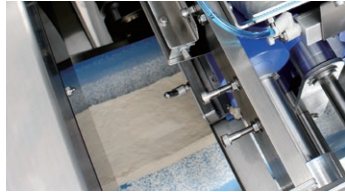
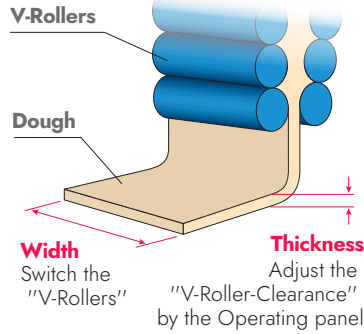

V-Roller Width : 115 mm

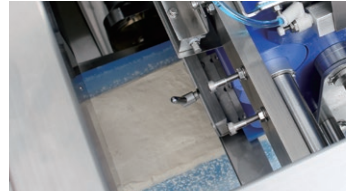

V-Roller Width : 145 mm

Accurate Weighing and Cutting System

Select from 1 or 2 rows without switching blades



1 row operation



2 rows operation

Easy Cleaning & Maintenance

Side covers open from both sides

- easy access, easy cleaning and maintenance



Operation side



Non-operation side



Conveyor belt and parts can be easily removed or installed

Options

Cup Rounder / SR002

Connected after the Divider. Produces divided dough into a complete round shape with a smooth surface for a high quality finish.

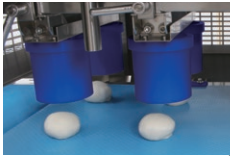

Punch Rounder / PR101

Punch Rounder produces handmade quality bread like a Meister. The dough is molded flawlessly into a round shape with the dough seam on the bottom.



Variety Molder / VR501

When connected to a dough divider such as the V4-Twin Divider, the divided dough balls can be stretched flat and formed into rolls.



Dimensions

(Unit: mm)

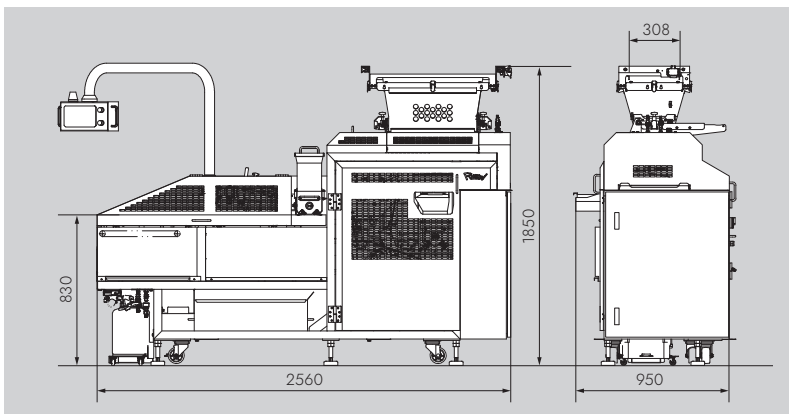

Specifications

Production Capacity	800 kg/h*1 (1000kg/h Max*2)	
Length	2560 mm	
Width	950mm	
Height	1850 mm	
Weight	900 kg	
Electrical Capacity	0.932 kW	
Air	0.5 MPa, 70 ℓ/m	
Hopper Capacity	55 ℓ	
V-Roller Width	Standard: 130 mm / Optional: 115 mm, 145 mm	

	1-row	2-rows
Dough Outlet Width	130 mm - 150 mm	65 mm - 75 mm
Dough Outlet Height	10 mm - 30 mm	
Dividing Range	150 - 1200 g	75 - 600 g
Output Speed (Max)	30 pcs/min	60 pcs/min (30 pcs/min x2)

The production specs may vary depending on the dough condition and characteristics.

*1 V-Roller Width set at W130mm

*2 V-Roller Width set at W145mm

The specifications are subject to change without notice and without obligation.

All Rights Reserved. Reproduction, adaptation or translation without prior written permission is prohibited.

RHEON

RHEON AUTOMATIC MACHINERY CO., LTD.

Head Office: 2-3 Nozawa-machi, Utsunomiya 320-0071, Japan
Phone: 028-665-1111 Fax: 028-665-3346 E-mail: info@rheon.com
URL: https://www.rheon.com

RHEON U.S.A.

2 Doppler, Irvine, CA 92618, U.S.A.
Phone: 949-768-1900 Fax: 949-855-1991 E-mail: us.info@rheon.com
URL: http://www.rheonusa.com

RHEON U.S.A. NJ BRANCH

700 Huyler Street Teterboro, NJ 07608, U.S.A.
Phone: 201-487-0600 Fax: 201-487-0610 E-mail: us.east@rheon.com

RHEON AUTOMATIC MACHINERY GmbH

Tiefenbroicher Weg 30, 40472 Düsseldorf, Germany
Phone: 0211-471950 Fax: 0211-424129 E-mail: de.info@rheon.com
URL: https://www.rheon-europe.com

RHEON AUTOMATIC MACHINERY GmbH ULM BRANCH

Saumweg 30, 89257 Illertissen, Germany
Phone: 07303-1599410 Fax: 07303-15994111 E-mail: de.info@rheon.com
RHEON AUTOMATIC MACHINERY CO., LTD. TAIWAN BRANCH
5F., No.118, Xinhua 1st Rd., Neihu District, Taipei City, Taiwan (R.O.C.)
Phone: 02-2792-3525 Fax: 02-2792-3529 E-mail: tw.info@rheon.com
RHEON AUTOMATIC MACHINERY CO., LTD. SHANGHAI OFFICE
ROOM30, 5F G1FCII, 1438Hongqiao Road, changning District, Shanghai
Phone: 86-21-61976378 Fax: 86-21-61976380

© RHEON AUTOMATIC MACHINERY 2019

No.S-FCVX-004-3C 24011000P (英/ヨーロッパ)