



 **WEXXAR BEL®**

BEL 505 V2

SEMI-AUTOMATIC CASE FORMER & PACK STATION

R&E

**ROBOTICS &
END OF LINE**

BEL 505 V2

SEMI-AUTOMATIC CASE FORMER & PACK STATION

BEL 505 INCREASES OPERATOR EFFICIENCY AND ERGONOMICS

The BEL 505 forms and holds cases in place for quick and easy 2 handed case packing.

Easy And Ergonomic Case Forming

The BEL 505 line of semi-automatic case forming and packing stations are a compact and ergonomic packaging solution for manual hand pack lines. When combined with a BEL case sealer, it allows one operator to form, pack and seal corrugated cases in a single operation.

The BEL 505 is a very versatile machine with many custom options and the ability to handle a range of case types and sizes. Its ease of maintenance and operation is also what makes this the perfect fit for low to mid volume applications looking for an entry level machine.



ABOUT THE BEL 505



EASY CASE SIZE CHANGES

Tool-less case size changes are simple and quick with change points accessible from both operational sides of the machine.

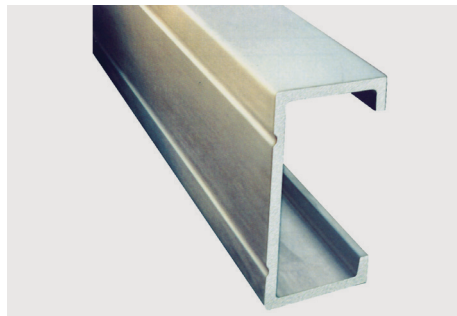

LASTING PERFORMANCE

Corrosion resistant and paint-free construction guards against machine wear and extends machine life.



ON MACHINE INSTRUCTIONS

User-friendly pictorial guides and color-coded labeling for convenient operation and size changes.

COMPLETE SOLUTION

FULLY AUTOMATE YOUR PACKAGING LINE WITH THESE FORMING AND PACKING SOLUTIONS.



BEL 150 CASE SEALER

Semi-automatic tape case sealer provides an effective and reliable solution for top and bottom sealing of a wide range of uniform case sizes.



ACCUMULATION TABLE

Ensures product is delivered continuously and ergonomically to the operator. This allows convenient and quick packing as it keeps the product in reach of the operator.



KDF BOX STAND

One of the most popular accessories for semi-automatic packaging lines. The box stand holds case blanks in a convenient position for quick and ergonomic packing.

CONFIGURATION

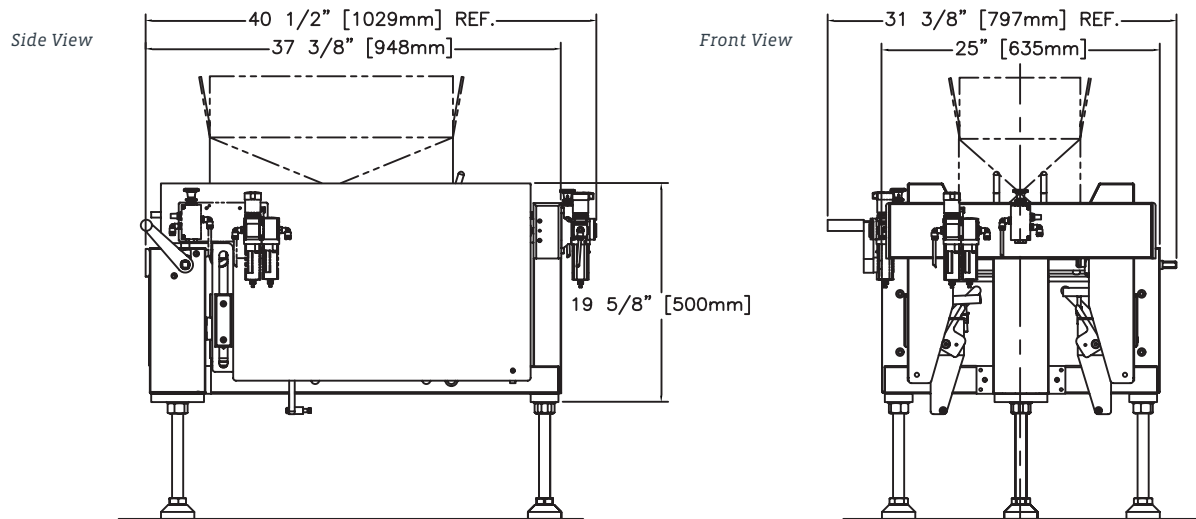

STANDARD FEATURES

- Dynamic flap-folding system power folds all bottom flaps
- Formed cases are positioned on a roller deck for easy loading and transfer to case sealer
- Positive mechanical case hold-down keeps box in place for hands-free loading
- Simple and quick tool-less changes for most case size
- Designed and built in North America with premium materials

OPTIONAL MODIFICATIONS

- Modifications for undersized or oversized cases
- Gap Flap or other case style modifications
- Water resistant washdown upgrades

OPTIONAL ACCESSORIES

- KDF Box Stand
- Locking Casters
- Outfeed Table or Conveyor
- Accumulation Table

PRODUCT SPECIFICATIONS

Machine Weight	250 lbs
Machine Dimensions	37.5"(L) x 25"(W) x 22.75"(H)
Air	0.1 cubic feet per cycle at 80-90 p.s.i.
Speeds	up to 15 cases per minute

Specifications are subject to change without notice.

*Note: Maximum speed is affected by case length, for specific capabilities consult with Sales.

CASE SIZE RANGE

	LENGTH	WIDTH	HEIGHT
Minimum	8" 203 mm	5" 127 mm	3 1/2" 89 mm
Maximum	26 1/2" 673 mm	16" 406 mm	unlimited

Oversize model available. Consult factory for case size ranges.

INFEEED/OUTFEED HEIGHT

Minimum	22.5" (572 mm)
Maximum	29" (737 mm)

Note: Casters add 4" to minimum and maximum height



At Wexxar Bel, corrugated container packaging applications are limited only by the imagination. Our Wexxar case formers and case sealers have been installed in nearly 40 countries and consistently bring customers the lowest cost of ownership and the highest standards of safety. Wexxar also offers the BEL line of corrugated box sealers, tapers, and packing systems as well as the IPAK line of tray and bliss formers, stackers, and sealers systems. As part of the ProMach End of Line business line, Wexxar helps our packaging customers protect and grow the reputation and trust of their consumers. ProMach is performance, and the proof is in every package.

13471 Vulcan Way

Richmond, BC, Canada

P: (604) 930-9300

F: (604) 930-9368

E: Wexxar@ProMachBuilt.com

Wexxar.com