

ZET-183

■ Description

The ZET-183 is a Z-bucket elevator fitted with a vibration feeder. Thanks to its gentle handling structure, it is suitable for conveying chocolates, confectionery, dry nuts, snack foods, pet products, frozen meats and other fragile industrial products.

The built-to-order ZET-183 allows the user to specify their in-feed and discharge requirements, with seamless integration to

upstream and downstream equipment.

Both the conveying capacity and feeder speed can be adjusted independently to maximise performance. The sanitary design reduces product changeover time and cleaning effort.

Robust and reliable, the ZET-183 conveys your product through continuous shifts.



■ Advantages

- ★ 1.8 litres food grade polypropylene buckets
- ★ Electrical compartment
- ★ Interlocking bucket design minimise product spillage
- ★ BOSCH REXROTH or PANASONIC inverter conveying speed control
- ★ Sanitary design
- ★ Simple and accurate chain tensioning adjustment
- ★ Single discharge chute
- ★ Solid stainless steel 304 construction
- ★ Vibration feeder with 60 litres hopper



■ Options

- Adjustment feet, chain, shaft and sprocket made of stainless steel 304 grade material
- C-bucket elevator
- Indexing drives
- Multiple discharge points
- Optional bucket materials
- Vibration feeder with 120 litres hopper
- Wash down structure
- Special voltage



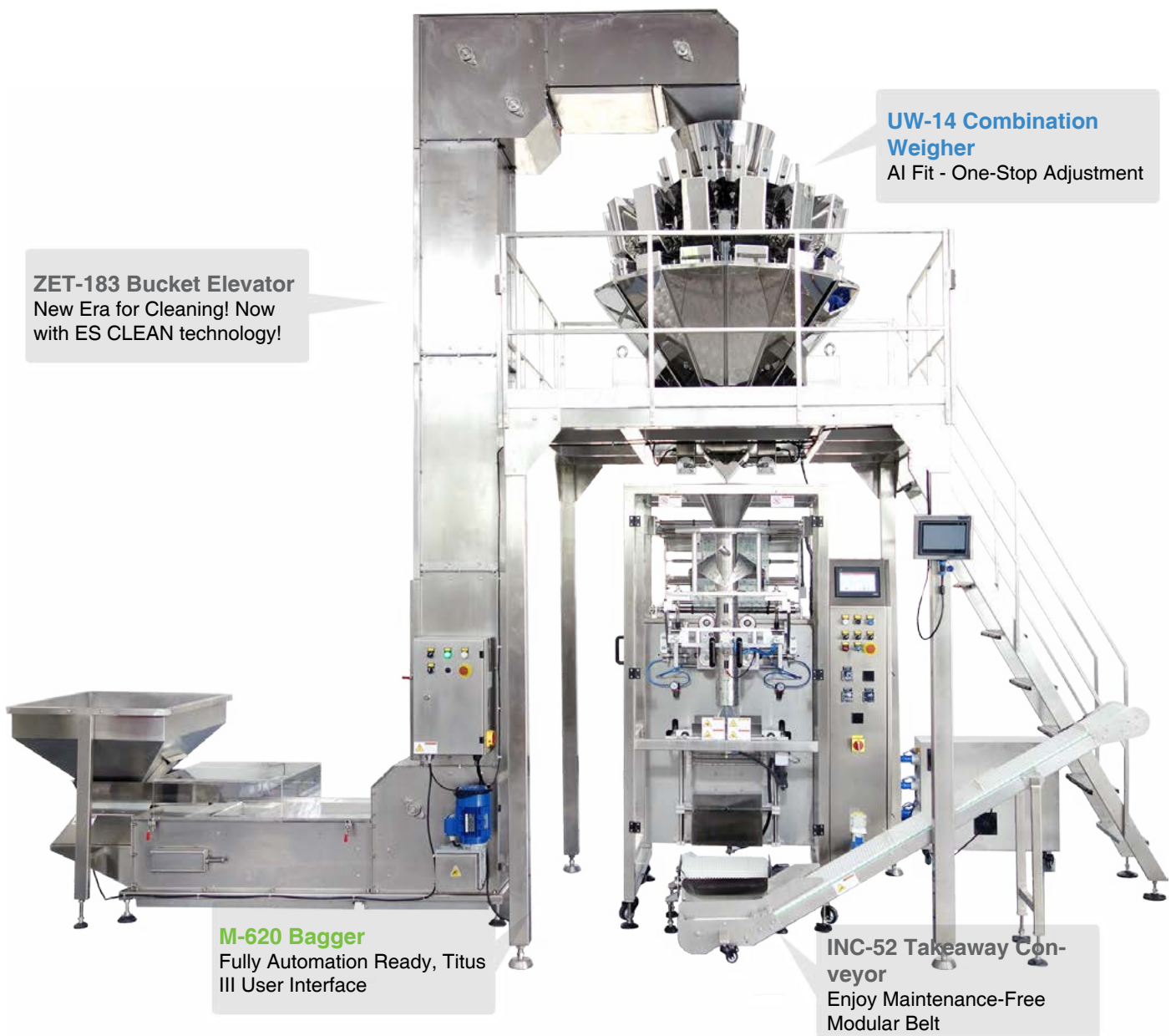

ZET-183 Bucket Elevator
New Era for Cleaning! Now with ES CLEAN technology!

UW-14 Combination Weigher
AI Fit - One-Stop Adjustment

M-620 Bagger
Fully Automation Ready, Titus III User Interface

INC-52 Takeaway Conveyor
Enjoy Maintenance-Free Modular Belt

Advantages

- ★ OMRON CP1 PLC control system
- ★ 7-inch OMRON colour touch screen
- ★ Multi-lingual operator interface with 24 product recipe
- ★ SCHNEIDER LEXIUM servo power dual drawn belts - servo performance and response on every pack
- ★ PANASONIC LX all colour photoelectric sensor for registered mark
- ★ OMRON E5 P.I.D. digital temperature controller
- ★ OMRON E6B2 encoder film length control
- ★ German SICK safety sensors
- ★ Teflon coated brass-made sealing jaws
- ★ Angled incline film unwind system
- ★ Tool-free quick change forming collar
- ★ Shaft-less reel mounted





Improves cleaning efficiency
(Right) Spillage tray and accessible rear cover

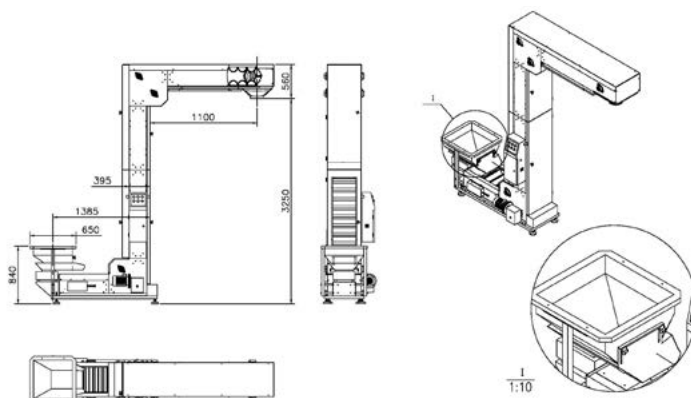

■ Technical Specifications

	Unit	ZET-183
<i>conveying capacity¹</i>	cbm / hr	≤ 10
<i>conveying height</i>	m	1 - 10
<i>machine weight</i>	kg	≥ 200
<i>machine dimensions</i>	mm	L3000 x W750 x H <i>built-to-order</i>
<i>power</i>	kW	1.0
<i>voltage</i>		230VAC, 50/60Hz, 1-Ph

note1: subject to product flow and density