

Horizontal Mixers

HM series

120 degree tilt

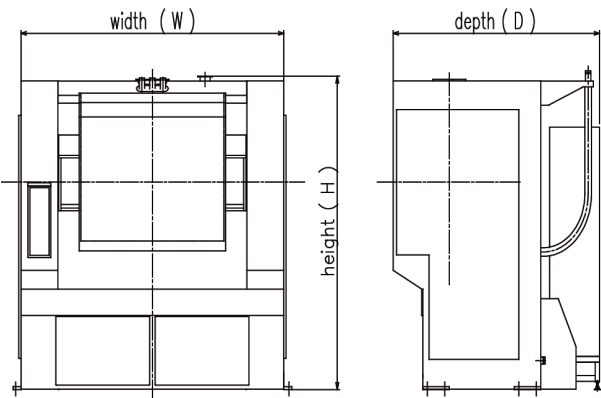

Model	HM1300-120	HM1600-120	HM2000-120	HM2500-120	HM3000-120	
Max.Dough Weight	lb.	1300	1600	2000	2500	3000
	kg	560	710	900	1125	1350
Agitator Rotation	rpm	75/37.5	70/35	70/35	70/35	70/35
Main Motor	HP	50/25	70/35	90/45	120/60	150/75
	kW	37/18.5	50/25	65/32.5	90/45	112/56
Dimensions (W) × (D) × (H)	in	109×84×99	109×93×107	118×93×107	120×109×116	125×109×116
	mm	2760×2125×2520	2760×2365×2730	2990×2365×2730	3050×2780×2940	3180×2780×2940
Machine Weight	lb.	18077	22046	24250	30093	35494
	kg	8200	10000	11000	13650	16100

*For HM200 - HM1000, please contact us.

140 degree tilt

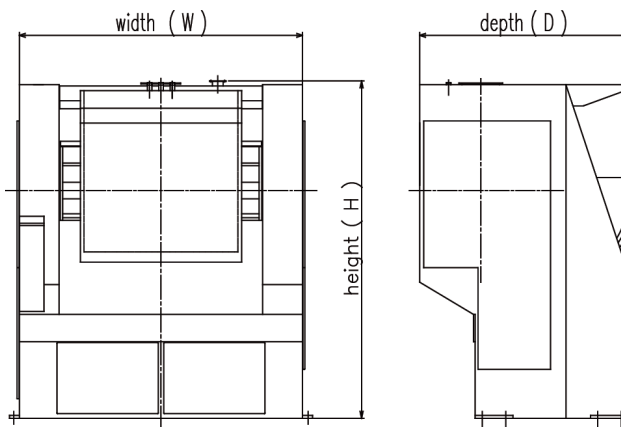

Model	HM1300-140	HM1600-140	HM2000-140	HM2500-140	HM3000-140	
Max.Dough Weight	lb.	1300	1600	2000	2500	3000
	kg	560	710	900	1125	1350
Agitator Rotation	rpm	75/37.5	70/35	70/35	70/35	70/35
Main Motor	HP	50/25	70/35	90/45	120/60	150/75
	kW	37/18.5	50/25	65/32.5	90/45	112/56
Dimensions (W) × (D) × (H)	in	109×82×97	109×90×112	118×90×112	128×108×119	133×108×119
	mm	2760×2090×2465	2760×2290×2840	2990×2290×2840	3240×2735×3030	3370×2735×3030
Machine Weight	lb.	19400	22046	24250	30069	39683
	kg	8800	10000	11000	15000	18000

*For HM200 - HM1000, please contact us.

Note) Maximum mixing weight calculated on soft dough with 82° F (28°C) and 64% water absorption based on sponge method.

Note) Refer to dimensional drawing for detail.

Note) Specifications and dimensions may be subject to change without prior notice.

Note) Supply voltage must be in accordance with the Country in which the Mixer is being used. (Transformer may be required)

Note) Minimum mixing capacity should not be lower than 50% of mixing capacity.

OSHIKIRI MACHINERY LTD. <https://www.oshikiri.com/>

Headquarter
4, Kirihara-cho, Fujisawa-shi, Kanagawa, 252-0811 Japan
Phone: 0466-44-6184 Fax: 0466-44-6187 E-mail: intl@oshikiri.com

Oshikiri Corporation of America
10425 Drummond Road, Philadelphia, Pennsylvania 19154-3898
Phone: 215-637-6005 Fax: 215-637-6041 E-mail: oshikiri-production@msn.com



OSHIKIRI Website
23.07.04 OSHIKIRI P-288-5

Tough and Heavy-duty Horizontal Mixers HM series

Time Tested Quality
since 1949

Model
HM200
HM300
HM500
HM600
HM800
HM1000
HM1300
HM1600
HM2000
HM2500
HM3000



Model HM1600-120T



Model HM800-95T



Model HM2500-140T

*Produces excellent and rich-in-volume
dough with the shortest mixing time.*

OSHIKIRI

Horizontal Mixers

Optimum mixing for excellent product

Agitator — Innovated Dough Punching & Kneading Design

Oshikiri Agitators are able to mix all kinds of dough, from soft to hard doughs.

For Soft Dough: YY2 Agitator or YY2A Agitator

For Hard Dough: YY1 with HP up motor

*Possible to use YY2 with HP up motor for Hard dough

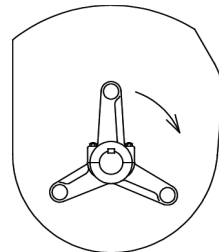

YY1

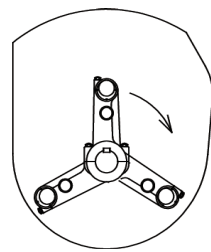

YY2

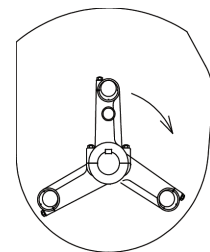

YY2A

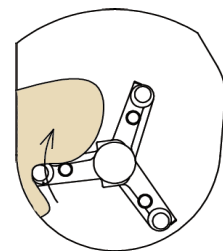

• CATCH DOUGH

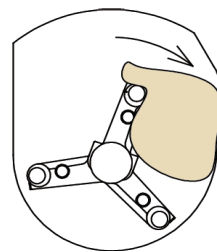

• PUNCHING
THROW DOUGH AGAINST
BACK SIDE OF BOWL

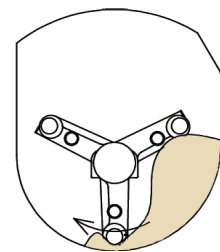

• KNEADING
STRETCH DOUGH AT
BOTTOM SIDE OF BOWL



YY1



YY2

95 degree tilt

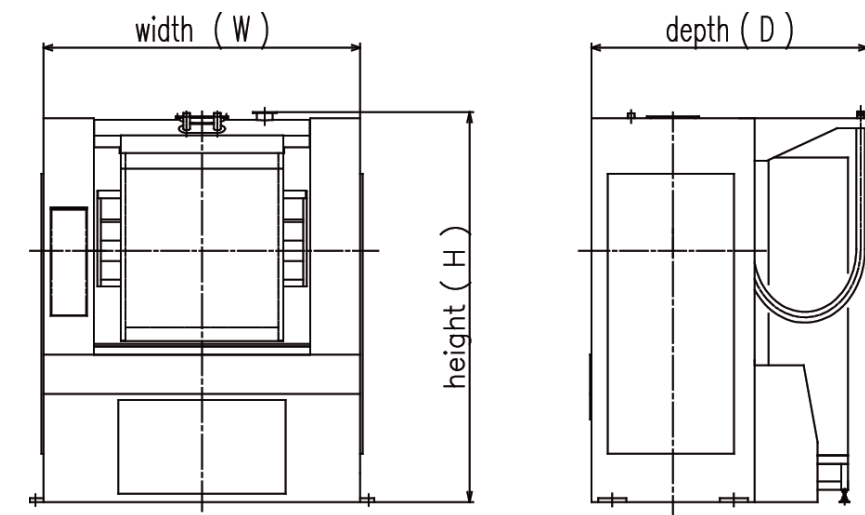

Model		HM200	HM300	HM500	HM600	HM800	HM1000
Max.Dough Weight	lb.	200	300	500	600	800	1000
	kg	90	135	220	270	360	427
Agitator Rotation	rpm	84/42	80/40	78/39	78/39	75/37.5	75/37.5
Main Motor	HP	10/5	15/7.5	20/10	25/12.5	40/20	40/20
	kW	7.5/3.7	11/5.5	15/7.5	18.5/9	30/15	30/15
Dimensions (W) × (D) × (H)	in	55 × 45 × 60	63 × 53 × 66	72 × 66 × 78	79 × 66 × 78	85 × 74 × 81	89 × 78 × 90
	mm	1380 × 1135 × 1530	1600 × 1335 × 1680	1840 × 1670 × 1970	2000 × 1670 × 1670	2150 × 1880 × 2060	2270 × 1990 × 2295
Machine Weight	lb.	2756	4410	6614	6945	12125	14330
	kg	1250	2000	3000	3150	5500	6500

Bowl Cooling Jacket — The Best Dough Temperature Control

Three types based on Mixer size and cooling specifications

- 1) Dimple
- 2) Horizontal Pass
- 3) Vertical Pass

All types offer the best cooling methods for the Mixer.

Both-face Clad-Steel is available for more efficient cooling.

PID Temperature control system is available.



Dimple jacket

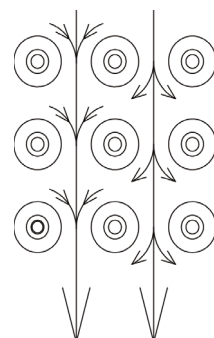

Eddy flow of Dimple jacket



Pass-through jacket

Model		HM1300	HM1600	HM2000	HM2500	HM3000
Max.Dough Weight	lb.	1300	1600	2000	2500	3000
	kg	560	710	900	1125	1350
Agitator Rotation	rpm	75/37.5	70/35	70/35	70/35	70/35
Main Motor	HP	50/25	70/35	90/45	120/60	150/75
	kW	37/18.5	50/25	65/32.5	90/45	112/56
Dimensions (W) × (D) × (H)	in	104 × 78 × 90	109 × 91 × 98	118 × 91 × 98	120 × 95 × 105	125 × 95 × 105
	mm	2640 × 1990 × 2295	2760 × 2320 × 2490	2990 × 2320 × 2490	3050 × 2420 × 2660	3180 × 2420 × 2660
Machine Weight	lb.	17637	19180	22487	29321	33069
	kg	8000	8700	10200	13300	15000

Design Your Mixer — Variety of Options

HM series



HM2000-120T



HM1600

- Stainless steel exterior and bowl
- Meets OSHA, BEMA and BISSC standards
- Touchscreen controls for ease of operator interface, timers, percent load meter, refrigeration control timers, dough temperature display, maintenance and diagnostic screens (Option)
- Hard wire push buttons with universal labels (emergency stop, power on, mixer start/stop, raise and lower bowl, jog, agitator)
- Two (2) hand control system for safety.

Special design options

- 120 or 140 degree tilt for easier dough discharge
- Dual flour inlets
- Multiple minor ingredient inlets
- Allen Bradley or Mitsubishi PLC
- Customized electrical packages

Main Shaft Seal — Sanitation

- CinchSeal available
Prevents dough leakage by adjustment of band.
Easy to inspect and make necessary adjustments.
- Separate Resin Seal
Newly invented Seal.
Easy to detach from main shaft, which makes it easy to inspect, adjust and clean.
Less risks of contamination.



CinchSeal



Separate Resin Seal

Dual Drive Mechanism — Heavy-Duty Mixing

- Dual drive mechanism prevents critical damage to motor and drive units.
Primary: V-Belt
Secondary: Chain or Timing Belt

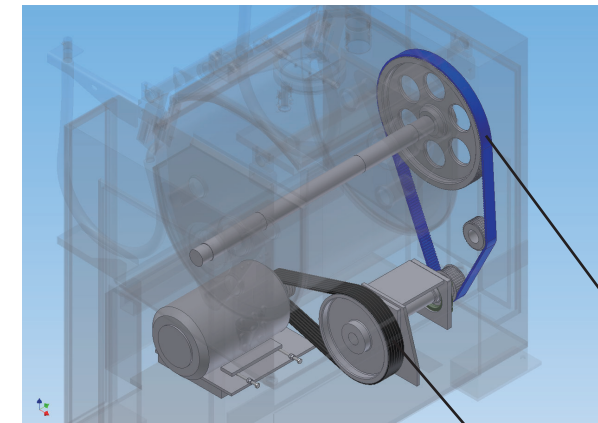

Drive Mechanism

Primary

Secondary

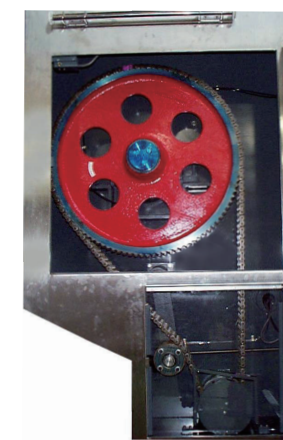

Chain

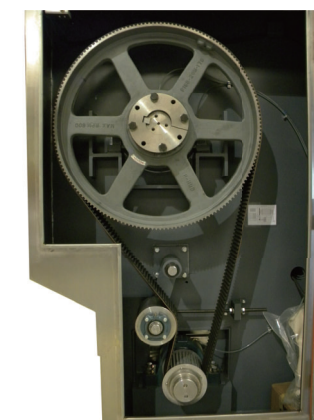

Timing Belt

Solid Bowl & Frame Structure— Guaranteed Durability

Solid structure of the mixer bowl and frame guarantees the Mixer's or impacts.

Multiple Motor Size — Lower Running Cost

Lower running costs can be achieved by choosing an Oshikiri Mixer because we use the appropriate motor based on the Customer's mixing specifications. The smaller the motor, the less power source for mixing is necessary. The same great results will still be achieved as with our larger Mixers. Please contact us for international markets.

Drainage Design — Hygienic Environment

Our standard drainage design provides a total hygienic environment. A water catch pan is entirely connected to a drain outlet located at the back. This preventative enclosed measure ensures no leakage. The outlet can easily be connected to your drainage equipment.



Drain inside of frame

Multiple Sizes — Suitable Mixing for High Quality

Oshikiri offers multiple sizes of Mixers for extra large scale commercial bakeries and manufacturers to small artisan bakeries and start-ups. They are designed respectively from 90 kgs/200 lbs to 1350 kgs/3000 lbs, for efficient, high-quality dough mixing of all types.

Pre-test at Oshikiri Lab — Discovery of The Best Method

Product Testing available at our Research & Development facility on several equipment lines from start to finish, including packaging. Various data can also be collected based on Customer's recipes and methods.



Mixing test



Slicing test

History — 70 Years of Innovation

Thousands of our units have been installed all over the world since 1949. Our Mixers have been the #1 choice, not only for sandwich breads, but for all bakery products: Hamburger Buns, Rolls, English Muffins, Pizza, Bagels, Frozen Dough, Pastries, Tortillas, Pita and Naan.



“ The first Mixer was developed to improve and eliminate hard work for the bakery industry. We have come a very long way since then.” — The Oshikiri Family