

REVISION HISTORY			
REV	DESCRIPTION	DATE	APRD
1	UPDATED PER ECO 0338.	7/25/2005	BCB

D  
C  
B  
A

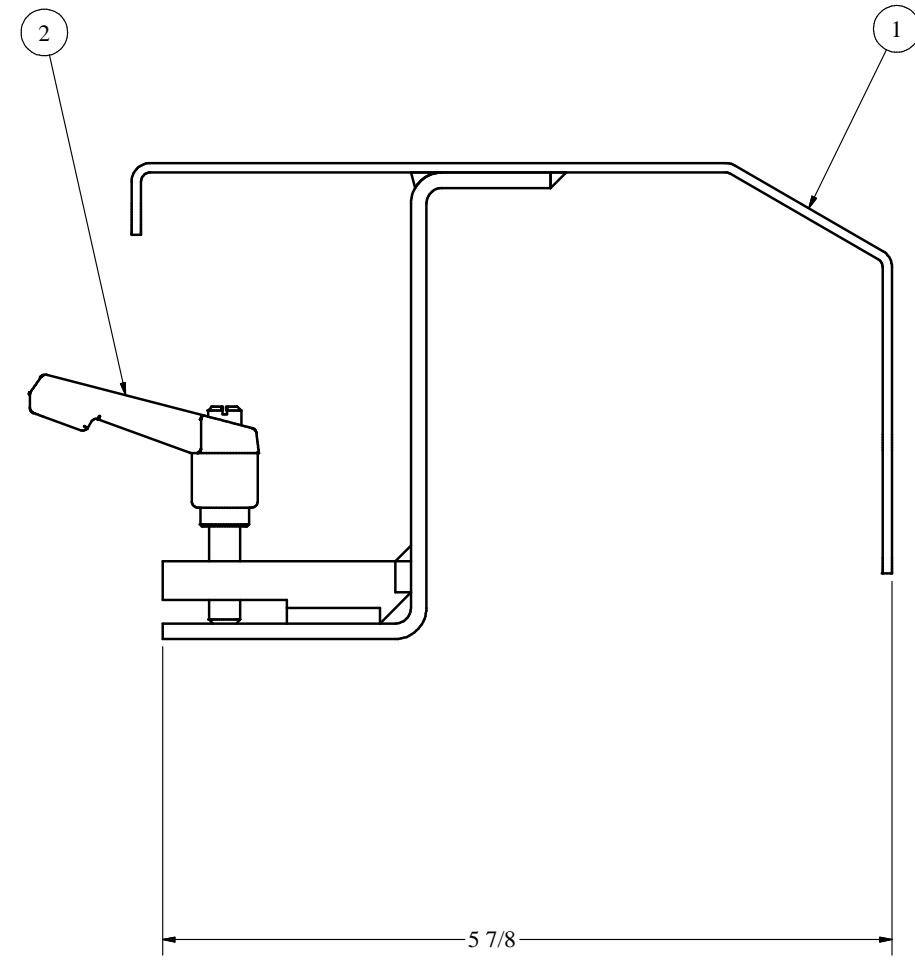
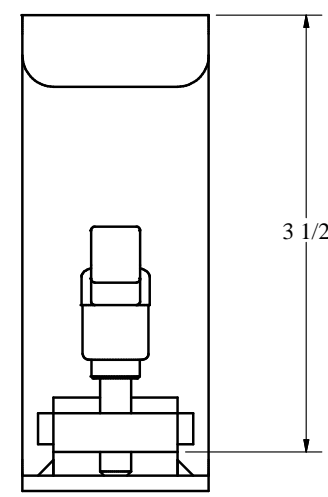
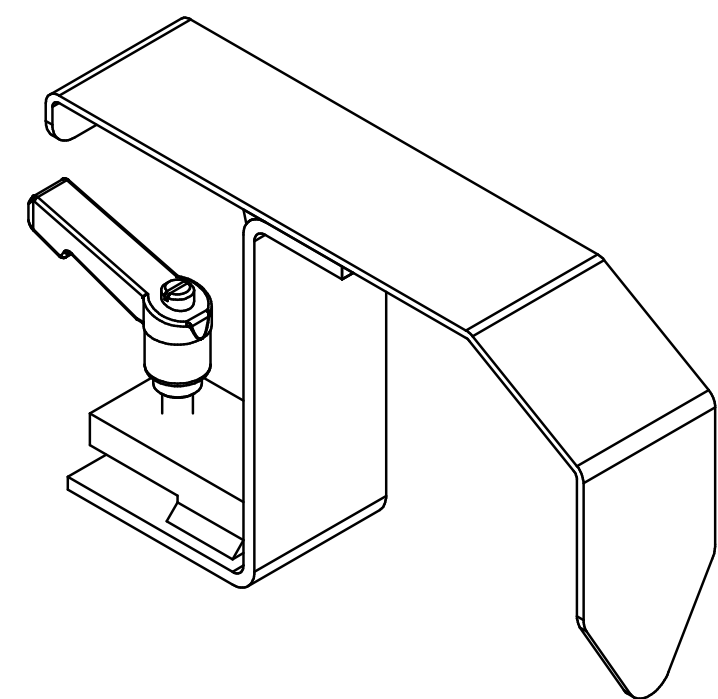
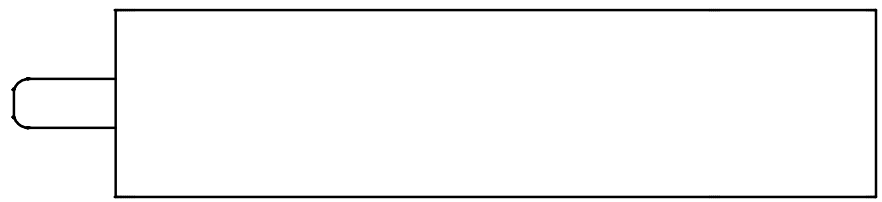

ITEM	QTY	PART NUMBER	DESCRIPTION
2	1	P0005931	SS ADJUSTABLE HANDLE 1/4-20 x .78L
1	1	M0031217	WLD - PRODUCT GUIDE

Parts List

This drawing and all information herein is the property of Rennco, Inc. and is confidential and must not be made public or reproduced by any means unless authorized by Rennco, Inc. and is subject to return upon demand.

MATERIAL:  
**NOTED ABOVE**

UNLESS OTHERWISE SPECIFIED TOLERANCES:  
 ANGULAR ±1°;  
 LINEAR .X=±.10°, .XX=±.01, .XXX=±.005  
 FRACTIONAL TOLERANCES:  
 LOCATION ±1/32";  
 HOLE DIA +1/64", 0"  
 BREAK ALL CORNERS R1/32"  
 SHEET METAL: BEND RADIUS 1/32"

**RENCO**  
 PACKAGING MACHINES AND SYSTEMS  
 23721 M60 W. - HOMER, MI 49245  
 PHONE: (517)568-4121 FAX: (517)568-4799 - WWW.RENNCO.COM

DESCRIPTION:  
**PRODUCT GUIDE ASSEMBLY E-PAC**

FINISH: NONE  
 ENG BY: DAR  
 W.O. NO.: S305  
 DRAWN BY: DAR  
 DATE DRAWN: 8/10/2004  
 CHECKED BY: DATE APRV:

SCALE: FULL C DRAWING NUMBER: M0031212  
 QTY REQD: 1 SHEET: 1

4 3 2 1